

## Development of Microcontroller-Based Automatic Voltage Surge Protection System

<sup>1</sup>Omofuma, O.I., <sup>2</sup>Sodiq K.A. <sup>3</sup>Theophilus, E.E. <sup>4</sup>Akinrogunde, O.O. <sup>5</sup>Thomas, T.G. & <sup>6</sup>Ifeka, O.I.  
<sup>1,3,4,5,6</sup>Ogun State Institute of Technology, Igbesa, Ogun State

<sup>1,3,4,5</sup>Department of Electrical/Electronics Engineering, Ogun State Institute of Technology, Igbesa, Nigeria

<sup>2</sup>Department of Computer Engineering, Yaba College of Technology, Yaba, Lagos, Nigeria

<sup>6</sup>Department of Computer Engineering, Ogun State Institute of Technology, Igbesa, Nigeria

Corresponding E-mail: kazeem23@yahoo.com

Corresponding Phone No: +2348055814510

### ABSTRACT

The inherent fluctuation in our power system due to lightning strike which brings about an unusual increase in the line voltage or the overloading of the consumer's power line by illegal connections have necessitated the need to protect basic electrical appliances such as the computer, television, home theater from damages. This research work however develop a microcontroller-based automatic voltage surge protector system which involves integration of the embedded systems technology using a PIC16F873A microcontroller, relay, battery unit, switches and Liquid Crystal Display(LCD), potentiometer and a buzzer. The potentiometer which is connected through the transformer to the microcontroller is used to calibrate the input voltage so that it can be used by the microcontroller to determine if it is low or high voltage. With the help of the program in the microcontroller, it determines the state of the voltage and displays it on the LCD so as to inform the user the abnormality in the voltage. On detection of high or low voltages, the microcontroller switches off the voltage output to our appliances to prevent them from being damaged by the power fluctuation. Once these abnormalities are detected, the microcontroller sounds an alarm with the aid of a buzzer to alert the users. It is recommended that all electrical appliances are protected with use of the system.

**Keyword:** Microcontroller, PIC16F873A, Lightning, Overloading, Appliances, LCD

---

#### 25<sup>th</sup> iSTEAMS Trans-Atlantic Multidisciplinary Conference Proceedings Reference Format

Omofuma, O.I., Sodiq K.A., Theophilus E.E., Akinrogunde O.O., Thomas, T.G. & Ifeka O.I. (2020): Development of Microcontroller- Based Automatic Voltage Surge. Proceedings of the 25th iSTEAMS Trans-Atlantic Multidisciplinary Virtual Conference, Laboratoire Jean Kuntzmann, Université Laboratoire Jean Kuntzmann, Université Grenoble, Alpes, France June, 2020. Pp 175-186 [www.isteams.net/France2020](http://www.isteams.net/France2020).

---

### 1. INTRODUCTION

The protection of our basic electrical appliances such as the computer, television, home theater, etc. has become a growing necessity as a result of the unavoidable surges in transient voltage which flows from power supply or electrical power (Elprocus, 2013). One of the forms in which a voltage surge can occur is by a lightning strike which brings about an unusual increase in the line voltage. Another form of protection of our basic electrical appliances such as the computer, television, home theater, is from low voltage which can result from over loading of the consumer's power line by illegal connections (Electronicsbeliever, 2017). Every form of voltage protection system is based on various types of technology which brings about a distinction in such system.

This research work focuses on the use of embedded system technology which deals with the connection of an unprotected voltage source to a Peripheral Interface Controller (PIC) microcontroller which is used to monitor the changes in the level of the voltage. A potentiometer is used to calibrate and to vary the voltage being monitored by the microcontroller. Interfaced to the PIC microcontroller is a Liquid Crystal Display (LCD) which is used to display voltage detected by microcontroller. An output voltage is obtained by the use of a relay which is connected to the microcontroller Prasad et al(2014).

Some of the importance of this system are; LCD display can be accurately viewed at greater distance than most traditional display. They are also bright enough to be seen in high ambient light condition making them ideal for use outdoor. The power consumption for a Microcontroller and the LCD is less hence making the system power friendly. It allows for the automatic operation of the system through the use of Microcontroller. The overall weight of the system is reduced with the use of Microcontroller. The maintenance of the system is reduced due to the use of fewer components.

This research work therefore shows the various stages and requirements that are involved in the use of a PIC microcontroller interfaced with an LCD for the protection of electronics appliances from voltage surges. It specifically monitor the voltage input from an unprotected voltage source, switch off the voltage output on occurrence of a voltage surge or occurrence of low voltage by the use of the microcontroller to turn off the relay, display the voltages on the LCD at various points and Sound a buzzer on occurrence of a fault

## 2. REVIEW OF RELATED WORKS

### 2.1 Voltage Protector

This is used to protect electrical devices from a sudden voltage increase. It attempts to limit the voltage which is supplied to electric device by shorting to ground or blocking any unwanted voltages above safe threshold. Appliances can be damaged by electrical surges by wearing down or burning its wires the devices internal components.

### 2.2 Basic Components of a Voltage Protector

Various components make up a voltage protector system but the basic components are the potentiometer, microcontroller unit and the LCD display unit.

#### 2.2.1 Potentiometer

This in electronics technology is called a pot which is a component, a sliding contact three- terminal resistor which forms a voltage divider which is adjustable. A pot is a voltage divider which is used for variation of electric potential i.e voltage in measurement and circuit theory. Pot is an electrical resistor which has three terminals which is a manually adjustable. Potentiometer establishes levels of output in many electrical devices.

#### 2.2.2 Microcontrollers

This is a single-chip computer. The Micro in the word suggests that it is small, and the controller suggests t it is usefulness in control applications. Embedded controller is another term used for Microcontroller and they are built in the devices in which they control. The main difference between microcontroller and microprocessor, is that microprocessor needs many components to operate; these components include data memory, program memory, external clock circuit and input-output devices. While in a single chip ,all the support chips are incorporated in the case of microcontroller. This is shown in figure 1 below.

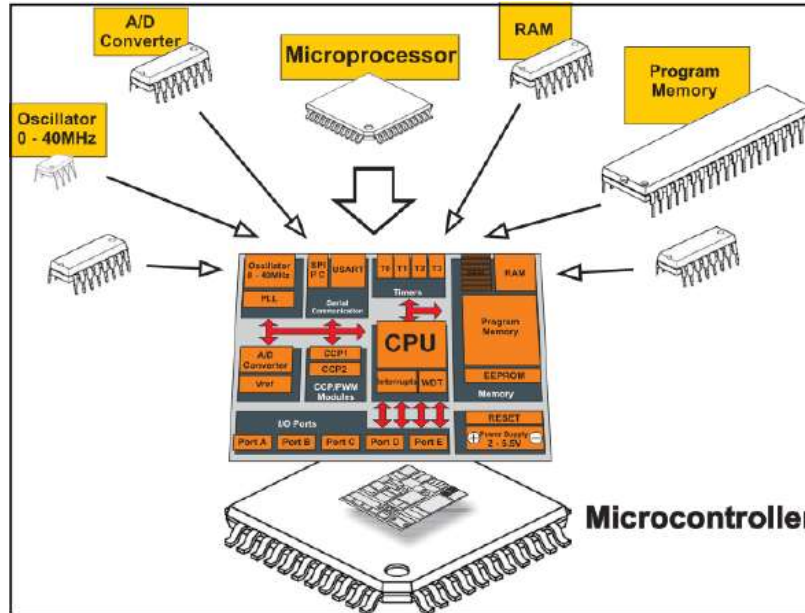
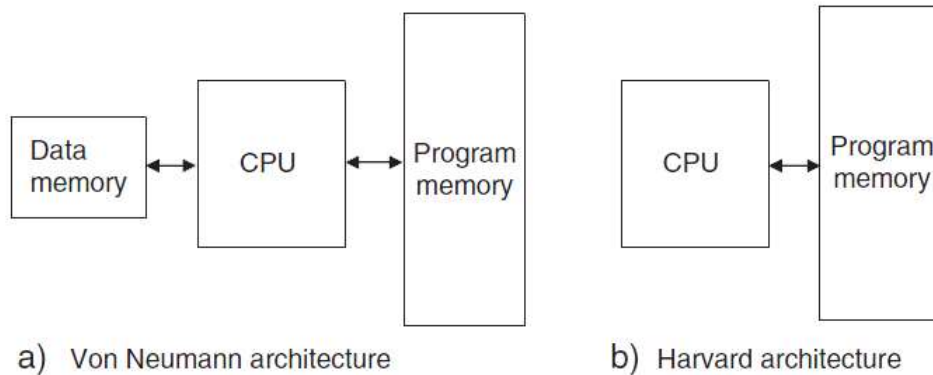

Figure 1: Microcontroller versus Microprocessor

Microcontrollers operate on user program i.e a set of instructions which is stored in their memory. One by one, microcontroller fetches instructions from its program memory, it then decodes instructions and subsequently carries out required operations. (Dogan, 2008). Microprocessor, memory and input-output constitute the simplest microcontroller architecture. Microprocessor is a central processing unit and it is brain of microcontroller which consists of Arithmetic and Logic unit(ALU), control unit(CU) and memory unit. The ALU is where arithmetic and logical operations are performed. The CU controls the internal operations and sends signals to the various parts of the microcontroller so as to carry out necessary required instructions.

### 2.2.1 Microcontrollers Architecture

Von Neumann and Harvard architecture are the basic types of microcontroller architecture. This is as shown in figure 2 below. A single common memory space is used for storing both program instructions and data in Von Neumann architecture. It has single data bus that fetches both data and instructions. Each time central processing unit gets program instruction across the bus, it performs the corresponding operations by writing or reading from the data memory space. It then waits until the following operations are completed before fetching and decoding of the next program instruction. Economy and simplicity are the advantages of this architecture. But its bus is extremely congested. Data memory and program memory are separate memory and are accessed with separate buses in Harvard architecture. The data buses (internal) allow simultaneous access to both data and instructions. The central processing unit fetches instructions on program memory bus while it uses for its data operation the data bus. The data memory is on independent bus which can be read or written while program memory is being accessed, thus allowing execution of one instruction while next instruction is being fetched. It has an improved bandwidth, which speed up the time of execution which is at the cost of a more hardware complexity.



**Figure 2: Microcontroller Architecture**

### 2.2.2 Microcontrollers Memory

Data memory and program memory are the two types of memory in microcontroller system. Program memory is nonvolatile (no lost to data when power is off) usually and stores program written by programmer. Program memory stores the program written by the programmer and is usually nonvolatile (i.e., data is not lost after the power is turned off). On the other hand, data memory is volatile (data is lost when power is off) and usually stores temporary data used in a program (Dogan, 2014). There are six(6) types of memories basically and they are summarized as follows:

Random Access Memory (RAM) stores user data in a program and it is general purpose. Read Only Memory (ROM) usually holds fixed user data or program and it is nonvolatile. Programmable Read Only Memory (PROM) is a type of ROM that can be programmed by end user with the use of a device called a PROM programmer. Erasable Programmable Read Only Memory (EPROM) can be programmed with a programming device, and it is similar to ROM. Flash EEPROM is a version of EEPROM and since used in microcontroller applications popularly and also stores user program. Microchip (PIC series), Panasonic, Motorola (MPC series), Texas instruments, Atmel (AVR series), Actel, Sharp (ARM series), Maxim integrated products are some of the manufacturers of microcontrollers. The microcontroller can be programmed in any programming languages such as Assembly language, C, Basic and Pascal. Compiler is required to convert the code to machine language equivalent (Vangie,2020).

### 2.3 LCD Screen Interfacing

Microcontrollers generally lack video display which would make it more user-friendly. This video display also enable text messages, numeric values and graphics to be output versatile manner the more than alphanumeric displays or 7-segment displays LEDs. The cost of Standard video displays is relatively high and it requires complex interfaces. In microcontroller-based applications, LCDs are alphanumeric displays are frequently used. Display devices often come in different sizes and shapes. Some of the LCDs have capability to display many lines, and their character length could be forty or more. Some other LCDs can display graphic images with programming. In order to be viewed in dimly lit conditions to incorporate backlighting, some of the modules offer color displays. As far as serial and parallel interfacing technique is concerned there are two(2) types of LCDs basically.

### 3. METHODOLOGY

#### 3.1 Design

In designing a microcontroller based system to communicate with a software application and run in a specified environment, the first step for effective result is to develop a planned procedure to be correctly carried out. The process of production of the system is done by mounting a number of components such as; integrated circuits, transistors, resistors, capacitors, on circuit boards. For a final construction, a step by step method of manufacture was designed as shown in figure 3 below:

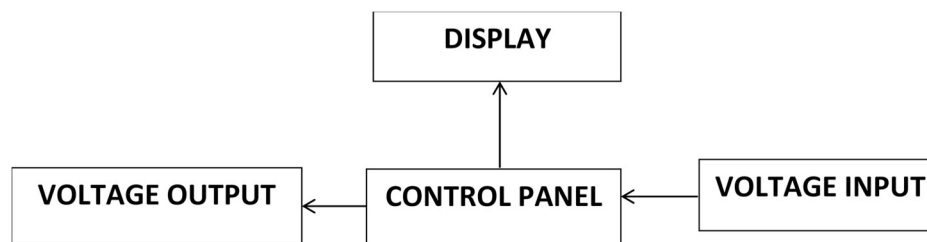

**Figure 3: Block Diagram of the Voltage Protector System.**

The process of the design actually involved the setting up of a power supply unit in hardware and then the design of the control panel in software and hardware. This involves developing a program code and then deploying the code into the microcontroller. Control panel then regulate the voltage output by controlling a relay to the voltage output and then feeds the LCD by sending out bytes of data to it which in turn display the information on the voltage levels. The detail of how each subsection is interconnected to another is given in the subsequent paragraphs.

#### 3.1.1 Hardware Design

The Hardware design first considers the selection of a suitable microcontroller and then the interconnection of the relay unit with the display system. This selection process involved gathering the relevant components for the research work. These components consist of the power unit, oscillator component, relay unit, potentiometer, microcontroller and LCD. In order to achieve a fully effective interfacing of the PIC microcontrollers with an LCD, careful considerations were made in the choice of the required hardware needed to develop the system. These factors include ; availability of the component in the local market, cost of the components with regards to its equivalent substitute; effectiveness of the component in performing its specified function. Under this, factors taken into consideration included its voltage rating, current rating, thermal resistivity, etc; speed of the component as a delay in the circuit may not produce the desired effect; noise Immunity of the component and storage capacity of some devices and a few others.

##### 3.1.1.1 Selection of Microcontroller Unit

Features of Microcontroller need to be of close matching as possible to the actual needs of the application because there is available range of microcontrollers. Among the features in consideration are number of the inputs and outputs ,development system support, program memory size, cost and availability. For this research work, the PIC range of microcontroller was used due to the fact it is easily available and cheaper than other embedded devices. Also, PICs are popular with hobbyist and developers due to larger user base, low cost, extensive collection of application notes, serial programming capability, wide availability and availability of low cost development tools.



In addition, it possesses all necessary features like analog to digital conversion (ADC), interrupt, enhanced universal synchronous receiver transmitter (EUSART) etc. needed to make the system work properly.

### 3.1.1.2 PIC Microcontroller

PIC is made by Microchip and it belongs to family of microcontrollers with Harvard architecture. The name PIC was referred to as “Peripheral Interface Controller” initially but now commonly called “Programmable Intelligent Computer”. It offers a wide range of input/output, memory and special functions to meet most requirements of the development engineer. For a PIC microcontroller to come on, some basic hardware connections must be made to the pins of the microcontroller. Since there are many PIC series, the basic connections with PIC16F873A are shown in Figure 4 below. These basic connections are the same for majority of the 28 pins 16F series PIC microcontroller.

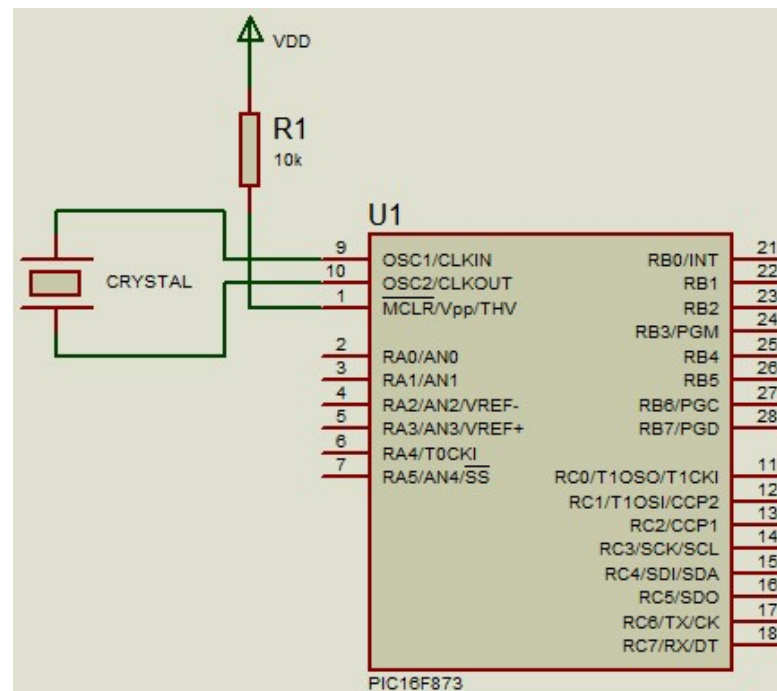

Figure 4: A PIC Microcontroller with Basic Requirements

### 3.1.1.3 Power Supply and Voltage Regulator

The power supply unit as shown in figure 5 comprises of a 9V transformer which takes supply from a 220V mains, a bridge rectifier consisting of four diodes for rectification of the voltage from A.C to D.C supply, a 5V regulator which is used to regulate the output voltage to a steady 5V which is useable by the system and two capacitors which are placed for filtering of noise by smoothing of the voltage wave.

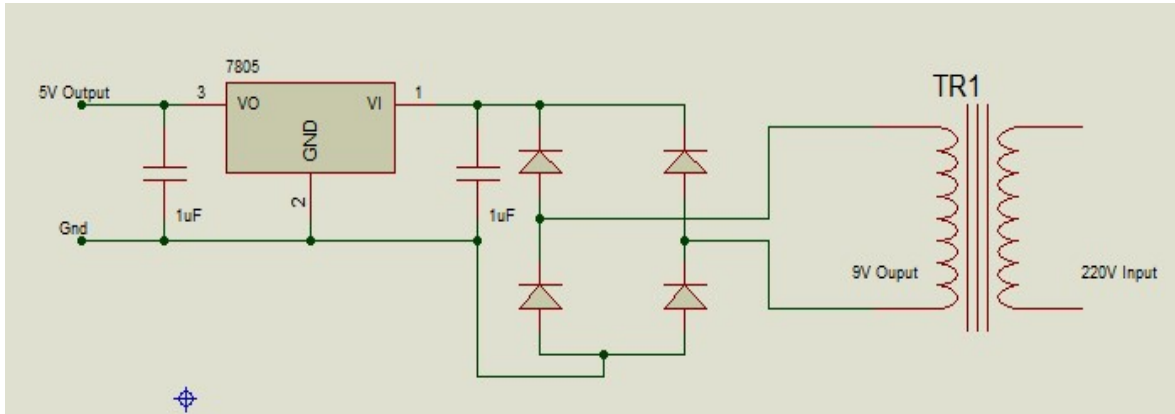

Figure 5: Power Pack for Voltage Input.

### 3.2 Software Implementation

Software for the PIC microcontroller was developed using Assembly language .MPLAB software was used because ; It enables easy addressing of the different ports and registers;It is faster for the MCU to process;It consumes lesser space compared to its high level equivalent;It enables the user to understand more of the microcontroller architecture; It is easy to learn since it implements the RISC structure.

#### 3.2.1 Programming Description

The following are the various stages involved in the programming for the automatic voltage surge protector:

#### 3.2.2 Configuration of the Microcontroller Pins as Input and Output

The following pins (RA0-RA4 for PORTA, RB0-RB7 for PORTB and RB0-RB7 for PORTC) serve as the pins through which the microcontroller is able to receive an input from a source or send an output to control a part. The appropriate codes must be written to the pins to configure them as either output or input. Pins RA1 and RA3 (Analog input of voltage), and RC0 (Clear flag) are set as input pins”1” while RB0-RB7 and RC1-RC3 are configured as output “0” to control the LCD for display are set as output pins with the following codes in which “1” means input and “0” means output. Pin RA2 (Buzzer to sound alarm) is configured as an output to sound an alarm.

#### 3.2.3 Configuration of the Voltage Range

The range of the voltage which is allowable as a safe voltage must be set so as to determine if the voltage is low, high or normal. The selected range of voltage that is allowed as the normal operating voltage is from 195V to 250V.

#### 3.2.4 Analog to Digital Conversion

For a microcontroller, there is a standard pattern for conversion of analog input into digital which can be displayed. An input voltage is an example of an analog signal which can be converted to digital by the microcontroller. The two stages involved are the receiving of the input voltage and the setting of the analog to digital conversion.

### 3.2.4.1 Receive the Input Voltage

The analog voltage input is gotten from the pin RA1 of the microcontroller. It is this voltage that is to convert to digital to determine if it is high, low or normal operating voltage.

### 3.2.4.2 Setting of the Analog to Digital Conversion

The following codes are used to configure settings of the analog to digital module of the microcontroller so that it can receive an analog voltage input.

### 3.2.5 Determination of the Voltage State

After the analog to digital settings have being made and the input voltage received, the microcontroller now determines if the voltage is low, high or normal operating voltage.

### 3.2.6 Protection Activity

The moment the microcontroller have determined the stage of the voltage, if it is high or low it switches off the supply of the voltage to the load through RC4 to protect the load from being damaged and if it is the normal operating voltage, it allows supply of the voltage to the connected load.

```

SHORT_DOWNLO    BCF PORTC,4                ;power down the system for low voltage
                  BSF PORTC,7                ;low voltage flag
                  CALL DISP_SHORT_DOWNLO
                  RETURN
SHORT_DOWNHI    BCF PORTC,4                ;power down the system for high voltage
                  BSF PORTC,5                ;high voltage flag
                  CALL PROTECT                ;disp_short_downhi
                  RETURN
POWER_UP        BSF PORTC,4                ;power up the system for normal voltage
                  CALL DISP_INPUT
                  RETURN
    
```

### 3.2.7 Displaying of Results on the LCD

For a microcontroller to send information to an LCD to display it has to first prepare the LCD for receiving as a standard means of operation which is known as initializing of LCD then it can send the information which the LCD is to display.

#### 3.2.7.1 Initializing of the LCD

The process of intialization of an LCD is just to make it ready to be able to display any information and this is usually performed each time a different information to be displayed by the LCD.

#### 3.2.7.2 Displaying an Output

To display any required information on the LCD, each of the alphabelt to be displayed will be sent to the LCD through the PORTB of the microcontroller.

### 3.2.8 Sounding of Alarm

To sound an alarm as an indication that a voter have voted or that the officials want to display the result, the microcontroller sends signal to RA2 (Buzzer to sound alarm) which is connected to the buzzer for sounding alarm.



## 4. HARDWARE IMPLEMENTATION

The process of construction of an automatic voltage protection system requires care so as to ensure that the system is able to perform the function that is required of it.

### 4.1 Procedure

All the materials needed for the research work were first purchased alongside with the tools before the beginning of the construction. The following procedures were followed in the construction of an automatic voltage protection system:

- Connection for the power system which consists of an input voltage source (220V AC) connected to a step down transformer which steps down the voltage to 9V. This 9V is passed through a bridge diode which rectifies the voltage from AC to DC voltage. This DC voltage is passed through a capacitor which acts as filter to remove noise. Through this capacitor the voltage is passed to a voltage regulator (LM7805) which is used to regulate the rectified voltage to a steady 5V which is useable by the system. This 5V is then passed through a capacitor to further filter any noise that could arise from the regulator. The positive output now stands as VDD (5V) for the system and the negative as the ground (GND).
- Mounting of the IC (microcontroller) base on the board. This is done so as to avoid soldering the microcontroller to the board because excessive heat can easily damage the microcontroller. The voltage input for the microcontroller pin 20 (VDD) is connected to the power supply positive terminal and the microcontroller ground pin 8, 19 are connected to the power supply ground (GND).
- A 10k resistor is connected through Pin 1 of the microcontroller to VDD (5V) this is to pull up the microcontroller to state HIGH for proper functioning.
- Mounting of the crystal oscillator on the board and connection of its ends to the pins 9 and 10 of the microcontroller.
- Because the system requires a form of display for all activities, an LCD is mounted on the board and connected to the pins 21-28 and pins 16-18. The LCD is also connected to 5V and ground of the power supply because it requires power to come on.
- The potentiometers are mounted on the board with one of its side connected to pins 3 and 5 of the microcontroller and the other ends connected to power (VDD) and to ground (GND). Also a potentiometer is connected to the LCD to vary its brightness.
- A relay is connected along the power supply and also to the microcontroller pin 15 through the use of a transistor and resistor.
- A buzzer is mounted on the board with one end connected to pin 4 of the microcontroller and the other end to ground (GND). This is used to sound an alarm when a voter votes or an official wants to check the result of the election.
- LEDs are mounted on the board and connected through a resistor to the microcontroller pins 16 and 18 to signify low voltage, high voltage and normal voltage.
- Finally push buttons are mounted on the board and connected to the microcontroller through the pins 11 and 17. These are used to clear off the low and high voltage flag.
- The whole circuit is then cased in a plastic case to enhance mobility and to prevent it from cutting easily.



## 4.2 System Operation

The overall operation of the system is such that the moment there is input voltage from the power supply, the microcontroller will check the value of voltage so as to determine the value of the voltage. If the value of the voltage falls within the allowable range of voltage, the microcontroller opens a relay to allow the flow of voltage output to connected load. The moment the microcontroller detects that the input voltage does not fall within the allowable voltage range, the microcontroller opens the relay to disallow the flow of voltage output. The microcontroller sends the value of the input voltage to an LCD for display. Some of the outputs of operation are as shown in the following figure 6 and 7.

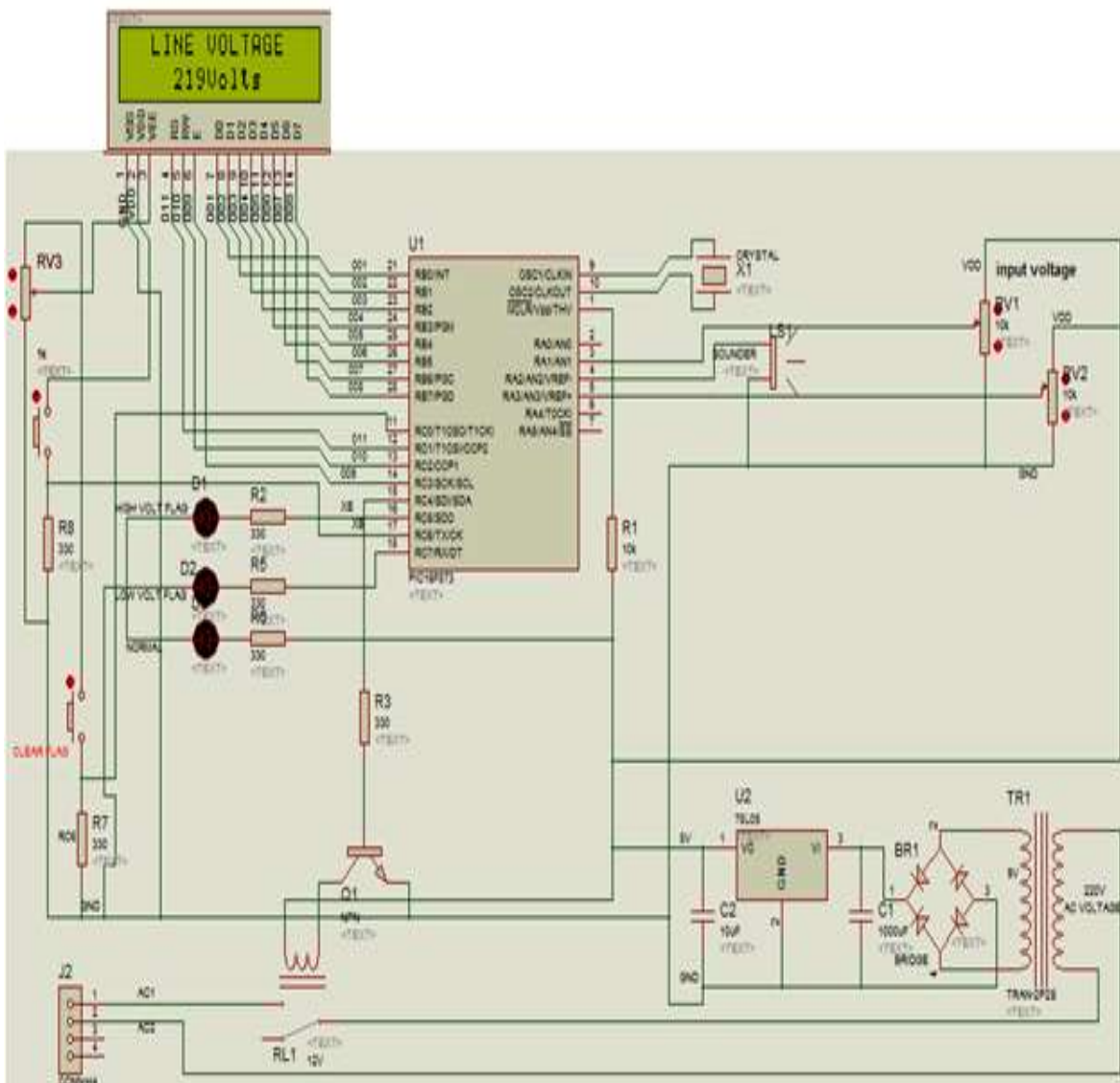

Figure 6: Normal Operation

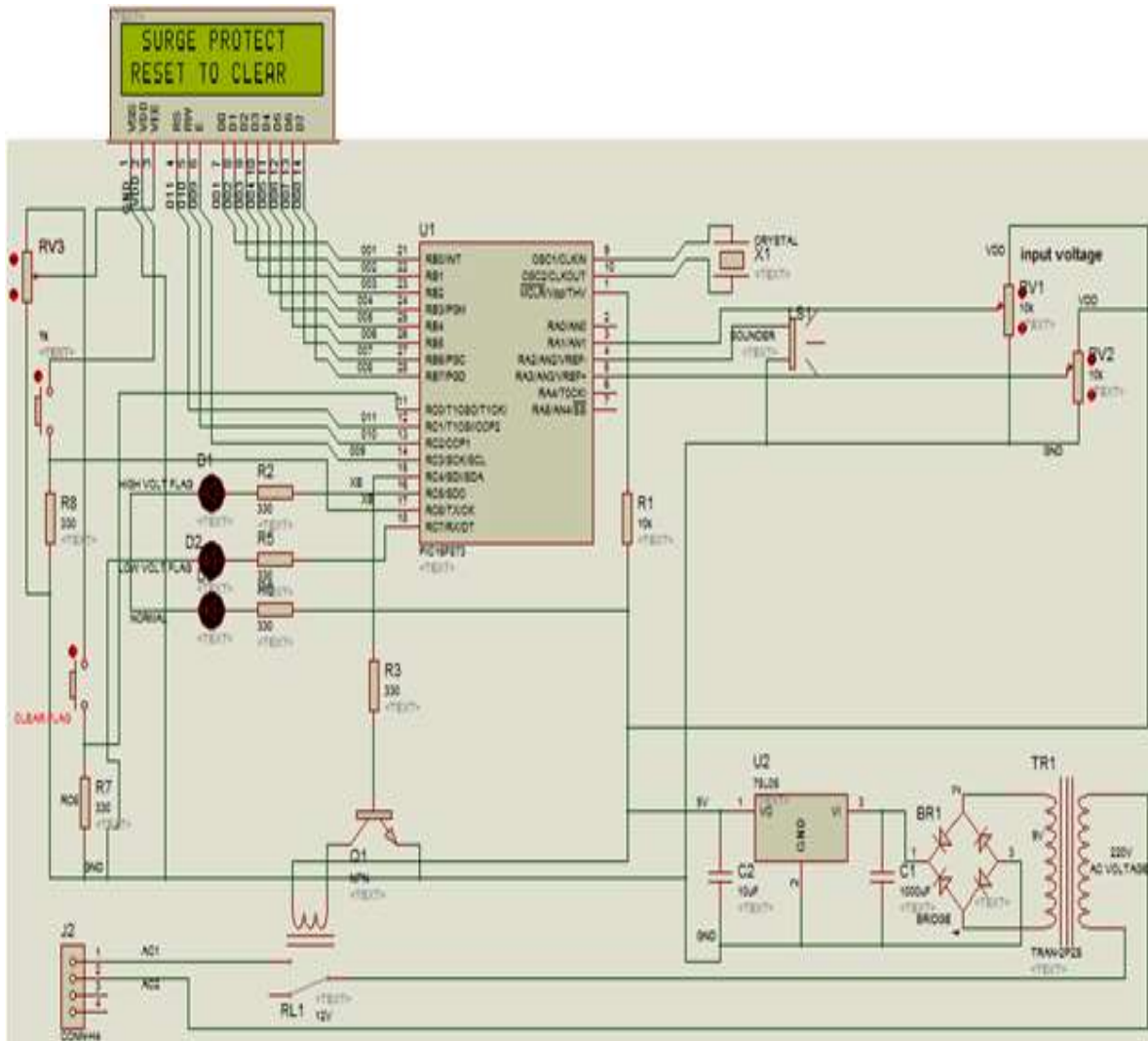

Figure 7: Surge Protection Operation

## 5. CONCLUSION

In this work, microcontroller was used as major component of the system. In many homes, surge protector might be missing due to the system cost. However, individual components might be inexpensive. Due to unavoidable surges in transient voltage or electrical power from power supply, the protection of basic electrical appliances is now a necessity. The system has capability of detecting high or low voltages, when this occurs, the microcontroller switches output voltage to appliances to prevent damages due to power fluctuation. The system LCD shows the abnormality in the voltage and system sound an alarm to indicate the level of the voltage.

## REFERENCES

1. Dogan, Ibrahim (2014).PIC Microcontroller Projects in C 2nd Edition Retrieved 22 June 2020 from <https://www.sciencedirect.com/book/9780080999241/pic-microcontroller-projects-in-c>
2. Electronicsbeliever (2017) Surge Protection Circuit Principle and Design Retrieved 2 June 2020 <http://Electronicsbeliever.Com/Surge-Protection-Circuit-Principle-Design/>
3. Leprous (2013). What is Surge Protector: Working and Its Applications Retrieved 23 June 2020 from <https://www.elprocus.com/surge-protector-working-and-its-applications/>
4. Narendra, Y. K., Prasad, B.B., Prashanth,S.V. Srikanth, V.& Lakshmu, N.T.(2014).Microcontroller Based Power Consumption Monitoring and Warning System Journal of Engineering Research and Applications ISSN : 2248-9622, Vol. 4, Issue 4( Version 4), April 2014, pp.121-128
5. Vangie, Beal (2020). Programming Language Retrieved 22 June 2020 from [https://www.webopedia.com/TERM/P/programming\\_language.html](https://www.webopedia.com/TERM/P/programming_language.html)