

An Energy-Aware Adaptive Transmission Scheme for Wireless Sensor Networks

A.I. Abdu, P.U. Okorie, E. Okafor, B.O. Sadiq & S.U. Hussein

Department of Electrical and Computer Engineering,
Ahmadu Bello University, Zaria,
Kaduna State, Nigeria.

{aiabdu@abu.edu.ng, tectex4sure@yahoo.com}

Abstract

In this paper, a scheme was proposed whereby the lifetime of a wireless sensor network is extended in which, each sensor node decides whether to transmit a message or not and with what range to transmit the message based on its own energy reserve level and the information contained in each message. The information content in each message is determined through a system of rules describing prospective events in the sensed environment, and how important such events are. The messages deemed to be important are propagated by all sensor nodes and with different transmission ranges depending on nodes energy resource level, while messages deemed to be less important are handled by only the nodes with high energy reserves level and transmitted with different transmission ranges based on nodes energy resource level. It is evident from the result that our proposed scheme achieves a significant improvement in network lifetime compared to other related energy saving schemes.

Keywords: Energy-aware; Wireless sensor-networks; Adaptive transmission ranges; priority balancing.

Aims Research Journal Reference Format:

A.I. Abdu, P.U. Okorie, E. Okafor, B.O. Sadiq & S.U. Hussein (2015): An Energy-Aware Adaptive Transmission Scheme for Wireless Sensor Networks. Aims Research Journal. Vol 1, No. 1 Pp1-10.

1. INTRODUCTION

A wireless sensor network (WSN) typically consist of a number of small, inexpensive, locally powered sensor nodes that communicate detected events wirelessly through multi-hop routing (Akyildiz, Su, Sankarasubramaniam, & Cayirci, 2002). These networks have limited computing capability and memory (Mini, Loureiro, & Nath, 2004). Typically, a sensor node is a tiny device that includes three basic components: a sensing subsystem for data acquisition from the physical surrounding environment, a processing subsystem for local data processing and storage, and a wireless communication subsystem for data transmission. A power source supplies the energy needed by the device to perform the programmed task. This power source often consists of a battery with a limited energy budget. In addition, it could be impossible or inconvenient to recharge or replay the battery, because nodes may be deployed in a hostile environment (Anastasi, Conti, Di Francesco, & Passarella, 2009). WSNs are being used in a wide variety of critical applications such as traffic, defense, medical treatment, manufacturing (Hill & Culler, 2002), military, health-care applications (Elrahim, Elsayed, Ramly, & Ibrahim, 2010), and environmental monitoring (Werner-Allen et al., 2006). A key research area is concerned with overcoming the limited network lifetime inherent in the small, locally powered sensor nodes (Akyildiz et al., 2002). Many of the WSN algorithms designed to extend the network lifetime are modified routing algorithms (Liu & Seah, 2004). However, a low cost and low complexity technique is the motivation of this study.

In this paper, a scheme to extend the lifetime of a wireless sensor network, named as AIRT (Adaptive Information managed energy aware algorithm for sensor networks with Rule managed reporting and Transmission range adjustments) is proposed. The extension in the network lifetime is achieved by adapting transmission ranges based on nodes energy reserve level and importance of messages. One main advantage of this scheme is that nodes do not have to transmit messages with their maximum transmission ranges all the time. The node's energy reserve level and message importance are taken into consideration, and therefore the node's transmission range is adapted accordingly.

The rest of this paper is organized as follows: Section 2 presents the related work. Section 3 presents the proposed AIRT scheme. Section 4 gives the performance study (simulation results and discussions). Section 5 provides conclusion and future work.

2. RELATED WORKS

In (G. Merrett, Al-Hashimi, White, & Harris, 2005), IDEALS (Information manage D Energy aware ALgorithm for Sensor networks) was introduced as a scheme that extends the lifetime of a WSN through the possible discrimination of low important messages and prioritizing important messages. The IDEALS scheme is built upon the idea of message priorities and power priorities. G. V. Merrett, Harris, Al-Hashimi, and White (2008) Proposed a localized technique to extend the lifetime of a wireless sensor network; referred to as IDEALS|RMR (Information managed Energy aware ALgorithm for Sensor networks with Rule Managed Reporting). The extension in the network lifetime is achieved at the possible sacrifice of low importance packets, as a result of a union between: Information control, quantified by a system of rules, referred to as Rule Managed Reporting (RMR) and energy management, supplemented by energy harvesting, for example, mechanical vibrations.

Two forwarding techniques were proposed by (Busse, Haenselmann, & Effelsberg, 2008) to maximize energy efficiency. The techniques are termed single-link and multi-link energy efficient forwarding. Single-link forwarding sends a packet to only one forwarding node; multi-link forwarding exploits the broadcast characteristics of the wireless medium. This leads to efficiency because if one node does not receive a packet, another node will receive the packet and performs the forwarding process. There is however a tradeoff of delivery ratios against energy costs. In (Abdu & Salamah, 2011), we extended the lifetime of wireless sensor network by sacrificing low importance message and also adjusting of transmission ranges based on only *nodes energy reserve*. However, in our proposed AIRT technique, we improved lifetime even better by adapting transmission ranges based not only on nodes energy reserve, but also on *message importance*.

3. THE PROPOSED AIRT SCHEME

The idea of our proposed AIRT scheme was first derived from (G. Merrett et al., 2005), where the basic principles of IDEALS was introduced as a scheme providing an increase in the lifetime of a wireless sensor network through the discrimination of certain messages. Additionally, the work of (G. Merrett et al., 2005) was extended by authors in (G. V. Merrett et al., 2008) through coupling IDEALS with a system for determining the messages information content - RMR. Furthermore, in our previous research (named as IRT) Abdu & Salamah, 2011), we extended (G. V. Merrett et al., 2008) by introducing adjustable transmission ranges based on nodes energy reserve only.

Finally, in this paper, we extended our previous work Abdu & Salamah, 2011) by

- Coupling IDEALS|RMR with Transmission Range Adjustment (TRA), whereby the Transmission Range is determined as a function of two parameters;
 1. Nodes energy reserve level and
 2. Importance of the message.
- Perform a detailed analysis through the simulation of the AIRT, IRT Abdu & Salamah, 2011), IDEALS|RMR and traditional (G. Merrett et al., 2005; G. V. Merrett et al., 2008) schemes to prove that the proposed AIRT technique is the most energy efficient.

The system diagram of the proposed AIRT scheme is shown in Fig. 1. Firstly, upon sensing data, the sensor node passes the information to the controller, which sends the sensed value (e.g. temperature) to RMR unit. The purpose of RMR unit is to determine if a message worth reporting has occurred and how important that message is. The value is then received by the *Rule Testing module*. Its responsibility is to determine if a message worth reporting has occurred. It does that by checking the sensed data against the rules in the *Rule Database* module (getting *history* information about the previously sensed values), at the same time, it updates the history with the current information of message and sensed message. Rules may be fulfilled or not, any rules which are fulfilled are passed to the *Message Priority Assignment Module* to determine how important the content of the message is.

It does that by assigning message priorities (MP) to each fulfilled rule. In this work, five different MPs are used (MP1-MP5). MP1 denotes the most important message which might represent drastic change in the sensed data value. Conversely, MP4 - MP5 relates to the least important messages which might represents slight or no change in the sensed value. MP2 - MP3 relates to intermediate priorities messages which might represent moderate change in the sensed value. Any number of predefined rules can be entered by the designer, and these rules describe different events that can be detected in the sensed environment.

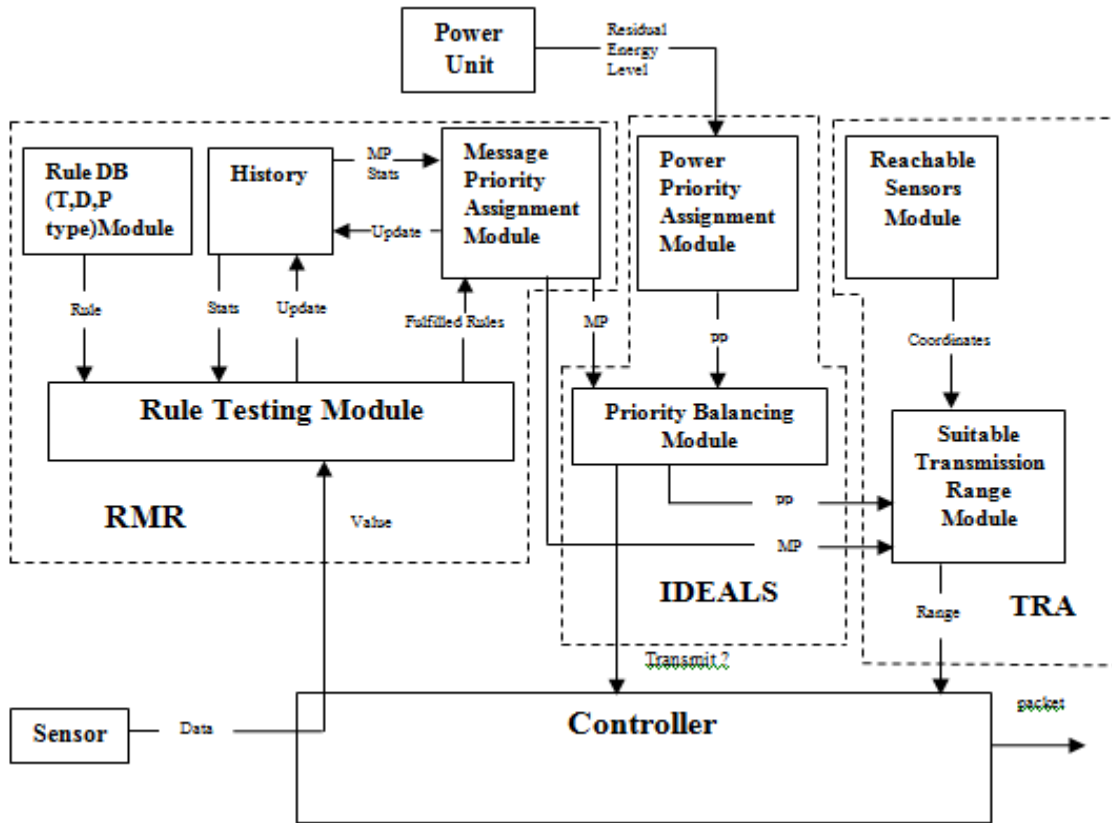

Fig. 1. The proposed AIRT system diagram.

Secondly, data from RMR is then passed to IDEALS unit, its responsibility is to decide if the node should transmit a message or not, and it's done by *Priority Balancing Module*. The node's energy resource is characterized by *Power Priority Assignment Module*, which assigns a power priority (PP) for each node based on the state of its battery. A full battery life is assumed to have 100joules of energy, whereas an empty battery life is assumed to be 0joules. The 100joules is divided equally into 5levels, and priorities are assigned to each level. The highest power priority is PP5 and it is assigned to the highest level of energy for a node which is from 80 to 100j. While the lowest power priority is PP1 and it is assigned to the lowest level of energy for a node which is from 0 to 20j.

When priority balancing module receives MP and PP, it compares them and if $PP \geq MP$, then the message will be transmitted as illustrated in the priority allocation and balancing process of Figure 2.

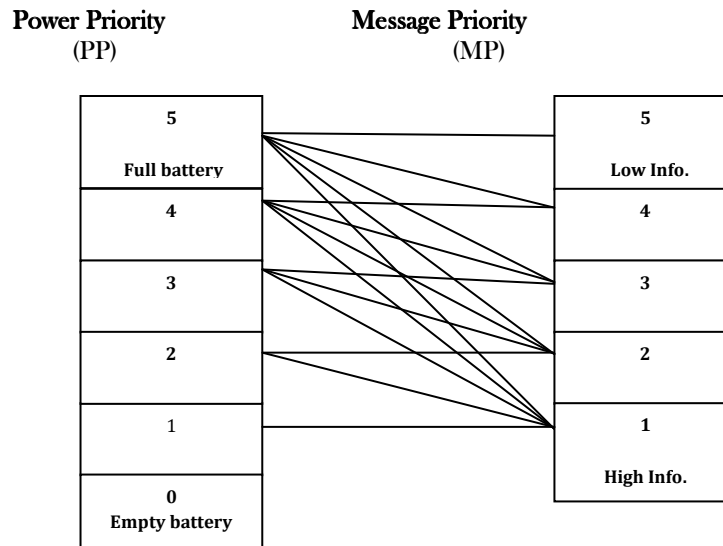

Fig. 2. Priority Balancing

Finally, PP and MP are also passed to the (TRA) unit in which the *Suitable Transmission Range* module decides with what range a sensor node shall transmit the message. The Suitable transmission range module gets PP from the power priority allocation module, MP from message priority allocation module and coordinates from *reachable sensors module*. The reachable sensors are the entire sensors in the maximum transmission range of a sending sensor node. Now, based on the value of the PP, and MP, a suitable transmission range (TR) is determined and passed to the controller to transmit the message with the new range as illustrated in the heuristic Table 1. In this work, five different TRs are used (TR1-TR5), where TR1 represents minimum transmission range and TR5 represents maximum transmission range. For example, when a node has full battery (i.e. PP5), it will transmit MP1 messages with TR5, MP2 with TR4, MP3 with TR3, MP4 with TR2 and MP5 with TR1. However, if a node's battery decreases to its minimum PP1, it will transmit only messages with the highest message priority MP1 and with the lowest transmission range TR1.

Table 1. Heuristically determined transmission ranges

MP \ PP	5 (Highest)	4	3	2	1 (Lowest)
5 (Lowest)	1 (Min. TR)	0	0	0	0
4	2	2	0	0	0
3	3	4	2	0	0
2	4	4	3	2	0
1 (Highest)	5 (Max. TR)	4	3	2	2

The transmission ranges in Table 1 above were determined heuristically after several runs of simulation with different values of TR. The resultant matrix has a meaningful structure which reflects the tradeoffs between MP and PP. These near-optimal TR values for the AIRT scheme improve the network lifetime, connectivity, and maintain a considerable message loss compared to other schemes (IRT, IDEALS|RMR, and Traditional) as will be seen in the performance analysis section. Table 1 can be seen as a matrix A with $i = MP, j = PP$, and $A [i,j] = TR$. Then, assuming that the number of levels used for MP, PP and TR is equal to L, the transmission ranges can be derived from the following algorithm:

$$A[i, j] = \begin{cases} 0 & \text{if } i > j \\ 2 & \text{if } i = j \text{ and } j \neq L \\ j & \text{if } i < j \text{ and } j \neq L \\ L + 1 - j & \text{if } j = L \end{cases}$$

4. PERFORMANCE EVALUATION

Performance evaluation of the proposed AIRT scheme is done through extensive simulation. To show that the proposed scheme conserves the most amount of energy, it is compared with other related power saving schemes based on Energy Depletion Times (EDT). Based on these performance metrics, the simulations of Traditional, IDEALS|RMR, IRT, and AIRT schemes are conducted.

4.1 Simulation setup

We simulated 20 sensor nodes in a network size of 70×70 meters. Each node has the same maximum transmission range of 20 meters. A predefined node placement topology has been considered in this study as it can be seen from Figure 4. At the beginning of the simulation, all nodes have the same initial energy of 100 Joules.

The following Equation (1) is used for calculating the energy required to transmit a packet:

$$E_s(l, d) = E_{elec}l + E_{amp}ld^{\alpha} \dots\dots\dots (1)$$

Where

$E_{elec}[J]$ is the energy required for the circuitry to transmit or receive a single bit, $E_{amp}[J]$ is the energy required for the transmit amplifier to transmit a single bit a distance of one meter, d is the separation distance in meters and l is the length of the packet. The simulation parameters are given in Table 2.

Table 2. Simulation parameters.

Simulation area	70×70 meters
Number of nodes	20 nodes
Packet length	1000 bytes
Initial node energy	100 Joules
Simulated Node Id	node-08
Minimum transmission range	13.04meters
Maximum transmission range	20 meters
Simulated node Coordinates	(x = 38 , y = 37)
Waiting time 't'	t minutes
Node 08 <i>Traditional Scheme</i> Result, for EDT performance Metric.	9 Hours
Node 08 <i>IDEALS/RMR Scheme</i> Result, for EDT Performance Metric.	34 Hours
Node 08 <i>IRT Scheme</i> Result, for EDT Performance Metric.	63 Hours
Node 08 <i>AIRT Scheme</i> Result, for EDT Performance Metric.	82 Hours

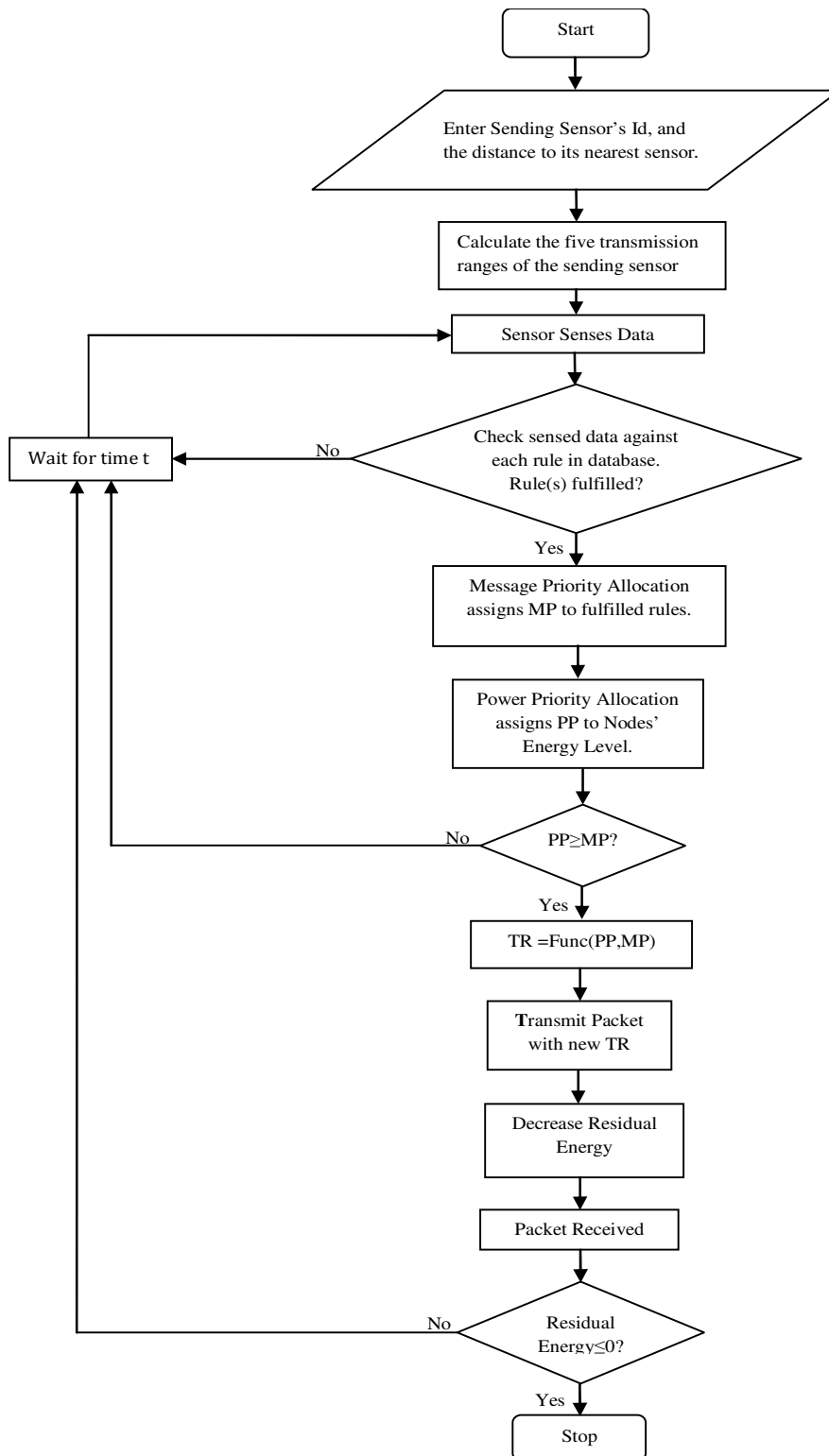

Fig. 3. Simulation Flowchart of AIRT scheme

Only one sensor node is chosen for the simulation as the remaining sensors are assumed to operate in the same way. The chosen sensor node id and the distance to its closest sensor node are given as inputs. The sensor node senses data and the AIRT algorithm is performed as illustrated in Figure 3. Since the maximum transmission range (TR5) is fixed for every sensor, the other transmission ranges can be calculated by considering the minimum transmission range (TR1) as the distance to the closest sensor in the sending sensor's maximum transmission range. So the ranges between TR1 to TR5 are calculated successively by adding $\Delta TR = (TR5 - TR1)/4$. That is, $TR(i) = TR(i-1) + \Delta TR$, for $i=2,3,4$. For example, adding ΔTR to TR1 gives TR2, and so on. To maintain connectivity, we took TR1 as the distance to the closest sensor in the sending sensor's transmission.

All nodes except the sink node (final destination of messages), performs multi-hop routing of messages by using the flooding algorithm. The simulation program is dynamic in the sense that, different coordinates from the ones used in the simulation can be entered and any node can be chosen for the simulation. Figure 4 shows a snap shot of a predefined node placement topology used in the simulation. Circles represent the maximum transmission range of sensors and lines represent possible communication link [10]. We chose node-8 as it is located in the middle. We assumed messages are transmitted every 5 minutes.

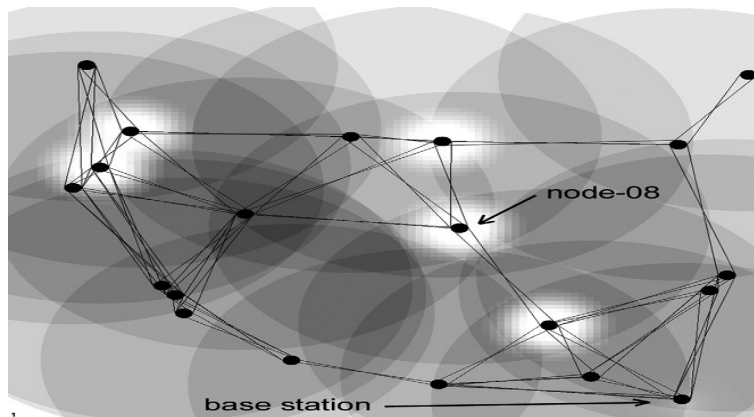

Fig. 4. A snap shot of node placement used in the simulation.

4.2 Simulation Results

Extensive simulation was done to show the effectiveness of the proposed AIRT scheme in extending the network life time. Furthermore, based on data priority (MP) and battery life (PP), a suitable transmission range is determined using Table 1.

4.3 Node Energy Depletion Times (NEDT)

Fig. 5 shows node-8 energy depletion times for all the four schemes. In the figure, '100' means that the node energy reserve is full, while '0' means that the energy reserve is depleted. For the traditional scheme, node-8 depleted its energy reserve after around 9h, this is because it is transmitting messages regularly every 5 minutes, and does not take into account the nodes energy reserve and message importance.

For the IDEALS|RMR scheme, it can be seen that the nodes energy level drops suddenly, this is because when the node has high energy reserve, it transmits every message that comes to it. The energy level then remains constant for a while because of less importance messages which are not transmitted. For the IRT scheme, the energy level drops and then remains constant because the IDEALS|RMR scheme is embedded inside IRT. However, the network lifetime increased almost twice that of the IDEALS|RMR due to the adjustment of transmission ranges based on the nodes energy reserve level. Finally, for the AIRT scheme, the same process of sudden dropping of energy level and then remaining constant occurs. However, the network lifetime is significantly enhanced compared to all other three schemes. The achieved improvements of the AIRT scheme over traditional, IDEALS|RMR, and IRT schemes are 720%, 135%, and 33% respectively. This is due to the fact that nodes are adapting their transmission ranges based on both their energy reserve level and message importance.

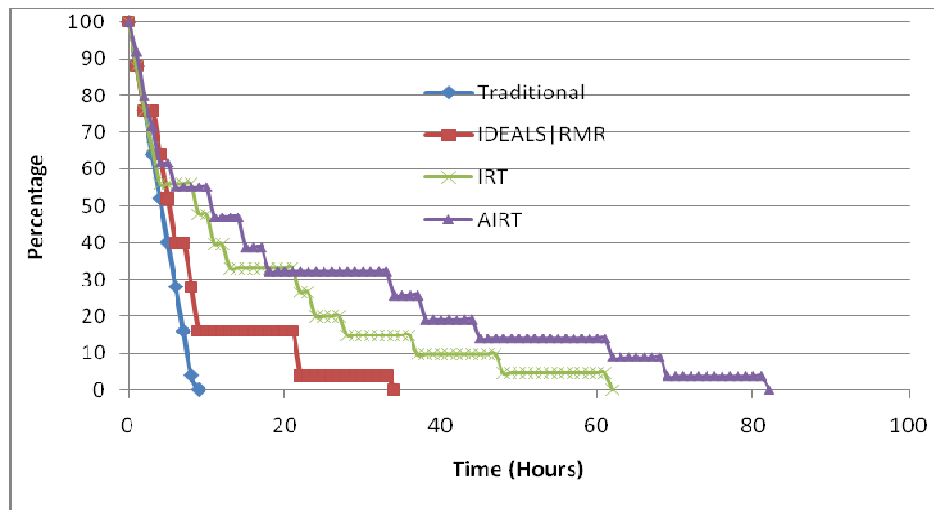

Fig. 5. Node energy depletion times.

5. CONCLUSION

In this paper, we introduced the AIRT scheme, which operates on the combination of information control (deciding if a message is worth processing based on the user defined rules, and how important the message is), energy management (balancing of the energy resource level and message importance) and transmission range adaptation (deciding on the transmission range based on nodes energy resource level and message importance) which we believe have never been considered before. Simulation was performed using C programming language where a single node was simulated to show the operation of our scheme. The results obtained show that the proposed AIRT scheme outperforms the other schemes (IRT, IDEALS|RMR, and Traditional) in terms of lifetime and connectivity. It is interesting to note that this improvement is achieved without significant change in the message loss.

6. DIRECTION FOR FUTURE WORKS

We are currently working on the coupling of the AIRT scheme with fuzzy logic in the sense that decisions on the MP, PP and TR values can be based on fuzzy logic.

REFERENCE

1. Abdu, A. I., & Salamah, M. (2011). Energy-aware transmission scheme for wireless sensor networks *Recent Trends in Wireless and Mobile Networks* (pp. 135-144): Springer.
2. Akyildiz, I. F., Su, W., Sankarasubramaniam, Y., & Cayirci, E. (2002). Wireless sensor networks: a survey. *Computer networks*, 38(4), 393-422.
3. Anastasi, G., Conti, M., Di Francesco, M., & Passarella, A. (2009). Energy conservation in wireless sensor networks: A survey. *Ad hoc networks*, 7(3), 537-568.
4. Busse, M., Haenselmann, T., & Effelsberg, W. (2008). Energy-efficient forwarding in wireless sensor networks. *Pervasive and Mobile Computing*, 4(1), 3-32.
5. Elrahim, A. G. A., Elsayed, H. A., Ramly, S. E., & Ibrahim, M. M. (2010). An energy aware WSN geographic routing protocol. *Universal Journal of Computer Science and Engineering Technology*, 1(2), 105-111.
6. Hill, J. L., & Culler, D. E. (2002). Mica: A wireless platform for deeply embedded networks. *Micro, IEEE*, 22(6), 12-24.
7. Liu, Y., & Seah, W. K. G. (2004). *A priority-based multi-path routing protocol for sensor networks*. Paper presented at the PIMRC.
8. Merrett, G., Al-Hashimi, B. M., White, N. M., & Harris, N. R. (2005). Information managed wireless sensor networks with energy aware nodes.
9. Merrett, G. V., Harris, N. R., Al-Hashimi, B. M., & White, N. M. (2008). Energy managed reporting for wireless sensor networks. *Sensors and Actuators A: Physical*, 142(1), 379-389.
10. Mini, R. A., Loureiro, A. A., & Nath, B. (2004). The distinctive design characteristic of a wireless sensor network: the energy map. *Computer Communications*, 27(10), 935-945.
11. Werner-Allen, G., Lorincz, K., Ruiz, M., Marcillo, O., Johnson, J., Lees, J., & Welsh, M. (2006). Deploying a wireless sensor network on an active volcano. *Internet Computing, IEEE*, 10(2), 18-25.

ABOUT THE AUTHORS



Abdullahi Ibrahim Abdu was born on the 5th of February 1987 in Kaduna State, Nigeria. He obtained his Bsc and Msc Computer Engineering degrees from Eastern Mediterranean University, North Cyprus. He is currently a Ph.D student and academic staff of Ahmadu Bello University, Zaria, Kaduna State, Nigeria. His area of interests are Computer Networks, Wireless Networks, Wireless Sensor Networks and Programming Languages.



Patrick U. Okorie received his B.Eng. in 1997 and M. Eng. in 2008 from AHMADU Bello University Zaria and Abubakar Tafawa Balewa University, Bauchi respectively. He is currently undergoing Ph.D. programme with the Department of Electrical and Computer Engineering of Ahmadu Bello University, Zaria and also a research fellow with same department. He interest in Power System Protection, control, fault diagnosis and reliability technology.



Emmanuel Okafor gained both his B.Eng in Electrical Engineering in 2010 and M.Sc in Control Engineering, 2014 from Ahmadu Bello University, Zaria, Kaduna State. He is currently a PhD student in Institute of Artificial Intelligence and Cognitive Engineering, Graduate School of Science, University of Groningen, Netherlands. His current area of research is in computer vision, machine learning and control of UAV system.



Sadiq Bashir Olaniyi was born in zaria, Nigeria on August 17, 1988. He is an indigin of Kwara State. He obtained his Bsc degree in Ahmadu Bello University, Zaria, Nigeria in 2011 and concluding his Msc in 2015 in the same university. He is currently an assistant lecturer in the department of Electrical and Computer Engineering, A.B.U., zaria, Nigeria.



Suleiman U. Hussein gained his B.Eng in Electrical and Electronics Engineering in 2006 from University of Agriculture, Makurdi, Benue State and M.Sc in Applied Instrumentation and Control, 2012 from Glasgow Caledonian University, Scotland, United Kingdom. He is currently a PhD student in Control Engineering from Department of Electrical and Computer Engineering, Ahmadu Bello University, Zaria, Kaduna State. His current area of research is in Control of non-linear systems, Sliding mode control and process control.