

GSM BASE Transceiver Station Placement Using Genetic Algorithm

Nwelih, E.

¹Department of Computer Science
University of Benin, Benin City Nigeria
E-mail(s): emmanuelnwelih@yahoo.com, ¹emmanuel.nwelih@uniben.edu.ng
Phones: +23480233964661

Asagba, P.O. & Ugwu, C.

Department of Computer Science
University of Port Harcourt
Port Harcourt, Rivers State Nigeria
E-mail(s): asagba.prince@uniport.edu.ng, ³chidiebere.ugwu@uniport.edu.ng
Phones: +23480348577812, +23480367311443

ABSTRACT

This study examines the issues of Global System for Mobile communication (GSM) networks in Nigeria which have made it possible to be connected and reachable even in the most remote places, and this has also increase the problem of base station transceiver placement. Literatures reviewed shows that 98% of GSM communication base stations in Nigeria are sited within 20 meters from residences, offices, schools, business buildings, petrol stations and public arenas. The challenges that necessitated this research are the problem of the location of Base Transceiver Station (BTS) in mobile telecommunication networks, excessive electromagnetic field which can be dangerous to people increases concern, because of the exposure of living organisms to more sources of electromagnetic fields from radio. In this study we will be discoursing the prospect of using Genetic Algorithm approach in placing Base Transceiver Station Neighborhood model in our environment by taking into consideration the health issues of the population living there.

Keywords: Global System for Mobile communication (GSM), Base Transceiver Station (BTS), Neighborhood Model and Genetic Algorithm (GA).

SMART-iSTEAMS Conference Proceedings Paper Citation Format

Nwelih, E. Asagba, P.O. & Ugwu, C. (2018): GSM BASE Transceiver Station Placement Using Genetic Algorithm. Proceedings of the 10th SMART- iSTEAMS Multidisciplinary Conference, February, 2018, Ogwuashi-uku, Delta State, Nigeria. Pp 1-8

1. BACKGROUND TO THE STUDY

Nigeria has been described in various ways as one of the fastest growing nation in the use of Global System for Mobile communication (GSM) by different researchers, Omirin and Olutuase, (2007), Udomisor et al. (2015) and Chieme and Obiora, (2014). The early periods of the new millennium, precisely year 2001, witnessed a revolution in the communication system in Nigeria as some Global Satellite Mobile (GSM) phone service providers were licensed to operate in Nigeria. This revolution has been largely enhanced by the aggressive market promotion of the GSM phone by the service providers who were quick to list various utility advantages of GSM services.



This ranges from making business transaction easier through facilitating quick information exchange to enhancing interpersonal relationships (Elegbeleye, (2005) and Joseph (2013)). There is no doubt that the telecommunication system in Nigeria has undergone a revolution since the deregulation of the market. Ever since then, there has been astronomical growth in the acquisition of cell phones by the youths, the grown-ups and even the aged. Given the mode of operation of GSM technology, Base Transceiver Stations (BTS) are required for the provision of GSM services. Consequently, network of base stations were established in areas that enjoyed the GSM services all over Nigeria.

However, there are claims that the masts used by telecom providers radiate Electromagnetic Field (ETF) rays which are injurious to health. radiations are linked to health hazards such as fatigue, headache, decreased concentration, dizziness, local irritation, tumour induction, sperm motility, morphology and viability, cancer, especially brain tumour and leukaemia, viral and infectious diseases according to Aderoju, et al. (2014), Bello (2010). Given these potential health impacts of BTS on humans, the Nigeria Communication Commission (NCC), seeing the robust growth in the sector, encouraged the entry of more mobile operators into the market in the year 2001(Olukotun et al. 2013 and Elegbeleye, 2005). But two of the federal government agencies in Nigeria, the Nigerian Communications Commission (NCC) and the National Environmental Standard Regulatory Agency (NESREA), engaged each other in a show of supremacy over how to use or not to use Nigeria's environmental space for telecommunication business purposes. While NCC certifies a five (5) meters distance and other requirements, NESREA insists on the established guidelines for national environmental standards for telecommunications and broadcasting facilities.

The guidelines provided for the establishment of BTS within a minimum setback of ten (10) meters from the perimeter wall (fence) of residential/business premises, schools and hospitals. Similarly, where there is no perimeter wall (fence), the BTS must be at a minimum of twelve (12) meters from the wall of residential, business premises schools and hospitals, as stipulated by its 2007 establishing Act. NESREA has consequently shut down a number of base stations that contravened its position Husain, et al. (2017) and Badru et al. (2016). In this work we considered the Nigeria environmental space in the design of the proposed model using Genetic algorithm approach.

The mobile telecommunication industry in Nigeria is growing and is still undergoing extraordinary changes brought about by the introduction of new technology according to Joseph (2013). The changes have led to an increase of BTS in cities, towns and villages in Nigeria. This led to the concept of neighborhood control in this work, which is the inclusion of consideration of the structure in the immediate environment (neighbor) in the selection of a suitable site for the BTS. Involves the consideration of many issues amongst which are availability of land, safety and health considerations, accessibility for maintenance purposes, issues of radio frequency requirements, capacity issues, line of sight and height of the neighboring building.



The key problem identified in the placement of base station in Nigeria is the manual inspection of proposed site by engineers. The present process of cell planning leaves the final decision of the Base Station Transceiver (BST) site in the hands of a team of radio planners, who take these decisions based on their experience. The final decision can be subjective, giving room for bias and not give opportunity for a wider consultation for other option. The importance of environmental consideration in BST placement has resulted in operator views by many with the notion of their placement requirement. The shutting down of a BST over regulatory breach has multiple effects as it results in loss of network coverage for the area and a big financial loss for the operator Aderoju, et al. (2014).

The neighborhood concept was born out of the need for more efficient and automated cell planning tool that takes compliance to regulation into consideration and gives the operator the opportunity to search for a larger space for a near optimal placement. In the presence of agitation and public concern for the installation of base station in residential area, in Nigeria however there is cooperation between the ministries of environment, health and the ministries involve with the telecommunication regulation in putting in place an acceptable legal and regulatory framework. In this work, we will be looking at the existing BST architecture and design a BTS architecture which will includes Genetic Algorithm (GA) for optimizing the placement of the BTS and taking the neighborhood into consideration in determining its location by BTS, with maximum and minimum distance from populated environment in Nigeria.

2. STATEMENT OF PROBLEM

In spite of the huge work carried out on the designing of the access part of mobile communication networks, there are still some problems which have not been completely studied. Like the neighborhood consideration of BTS placement problem in Nigeria communities, despite the legal frame work put in place by NCC and NESREA to check the maximum and minimum distance from populated environment in Nigeria. GSM operators still violate the rules and regulations; this work specifically deals with the importance of environmental consideration problem in the locations of base station in mobile telecommunication networks in neighborhoods of Nigeria

3. OBJECTIVE

The main objective of this study is to design the proposed model using Genetic algorithm and to investigate existing base station placement patterns policies in Nigeria vis-à-vis our proposed software.

4. METHODOLOGY

The method applied in this study is the Object Oriented System Analysis and Design method where an existing system is studied from the perspective of objects and similar objects are grouped as classes and their properties are handled as fields while their behaviors are treated as the actions or methods within the same bundle of object.

4.1 The Research Design

This study considered the architecture of other researchers since the inception of the base station transceiver mobile network and the work of Mouly and Pautet, (1991) was adapted. Figure 1 shows the neighborhood control design.

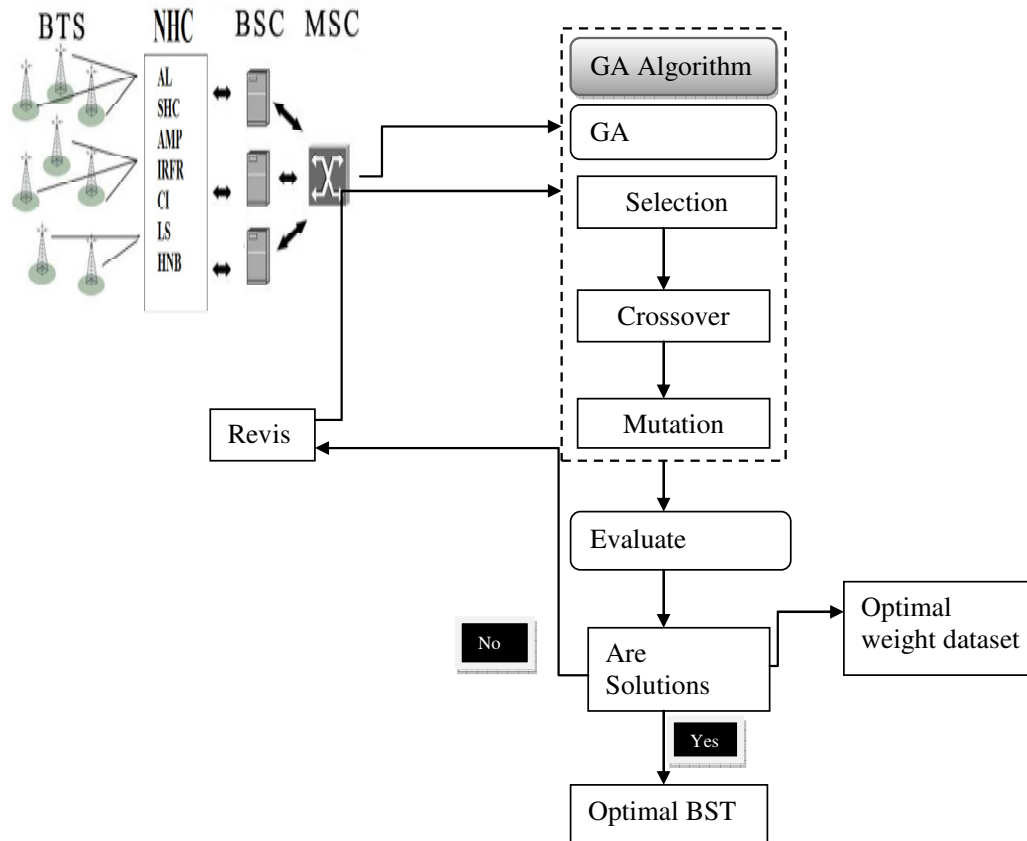

Figure 1: Neighborhood Control Design of the Proposed System

5. Detailed System Design

The proposed Neighborhood Control Design (NHC) of the Base Transceiver Station (BTS) concept consideration as shown in figure 2 is described in details as following:

Base Transceiver Station (BTS)

Base Transceiver Station is actually the antenna that you see installed on top of the tower. The BTS is the Mobile Phone’s access point to the network. It is responsible for carrying out radio communications between the network and the Mobile Phone. It handles speech encoding, encryption, multiplexing, and modulation/demodulation of the radio signals. One BTS usually covers a single 120 degree sector of an area. Usually a tower with 3 BTSs will accommodate all 360 degrees around the tower. However, depending on geography and user demand of an area, a cell may be divided up into one or two sectors, or a cell may be serviced by several BTSs with redundant sector coverage.

A BTS is assigned a Cell Identity. The cell identity denotes a particular Location Area, which provides details of the cell which the BTS is covering. Each cell covers a limited number of mobile subscribers within the cell boundaries (Coverage area). Approximately a Cell Radius is 30 Km, (Start up), 1 KM (Mature). The cell size determines the number of cells available to cover a geographic area and (with frequency reuse) the total capacity available to all users. Each network operator has a size cells to handle expected traffic demand.

Neighborhood Control (NHC)

The Neighborhood Control (NHC) is in charge of the geographic land mark futures, which helps the prospective network owners to place BTS within the control location. NHC consist of the following:

- Area type (AT)
- Availability of land (AL)
- Safety and health considerations (SHC)
- Accessibility for maintenance purposes (AMP)
- Issues of radio frequency requirements (IRFR)
- Capacity issues (CI)
- Line of sight (LS)
- Height of the neighboring building (HNB)

Base Station Controller (BSC): Base Station Controller (BSC) controls multiple BTSs. It handles allocation of radio channels, frequency administration, power and signal measurements from the MS, and handovers from one BTS to another (if both BTSs are controlled by the same BSC). A BSC also functions as a "funneler". It reduces the number of connections to the Mobile Switching Center (MSC) and allows for higher capacity connections to the MSC. A BSC may be collocated with a BTS or it may be geographically separate. It may even be collocated with the Mobile Switching Center (MSC)

Mobile Switching Center (MSC): Mobile Switching Center (MSC) is the heart of the GSM network. It handles call routing, call setup, and basic switching functions. An MSC handles multiple BSCs and also interfaces with other MSC's and registers. It also handles inter-BSC handoffs as well as coordinates with other MSC's for inter-MSC handoffs.

Genetic Algorithm (GA): Genetic Algorithms are based on the principle of evolution and natural genetics it has been successful in solving many optimization problems including the BTS placement problem. The design of a GA starts with solution encoding, creation of individuals that make a population, and evaluation of the individuals. During the evaluation each individual is assigned a fitness value according to a certain fitness function. Based on the fitness value, some of the better individuals are selected to seed the next generation by applying crossover and mutation to them. In GA, the variables can be represented in binary, integer, real, or integer and binary. This work considers the value encoding scheme. In other to evaluate the performance of the proposed algorithm, the network data will be given 64kbps uplink and 144kbps downlink data service will be used for the cell planning process which goes through the following;

Selection The selection was carried out to find out which individuals can be taken as parents for crossover. The individuals are selected based on their fitness values. An individual with higher fitness value is likely to be selected. The best six individuals are selected for crossover

Crossover The crossover produces new individuals in combining the information contained in the parents. Depending on the representation of the variables, different methods must be used. Basic crossover methods include one-point crossover, multi-point crossover, and uniform crossover. The uniform crossover is used in this thesis.

Mutation After the creation of all the children, the mutation operator possibly changes them. It scans each gene of all children and changes the value of a gene with the mutation probability. After the mutation process was finished the children needed to be evaluated. The best chromosome was then found and the algorithm started with selection again. The stopping criterion was fulfilled if the number of generations was reached.

Fitness simply defined is a function which takes a candidate solution to the problem as input and produces as output how “fit” or how “good” the solution is with respect to the problem in consideration. Calculation of fitness value is done repeatedly in a GA and therefore it should be sufficiently fast. A slow computation of the fitness value can adversely affect a GA and make it exceptionally slow.

6. CONCLUDING REMARKS

This study provides an insight into a developing country like Nigeria in terms of placement of Base Transceiver System for Global System for Mobile communication. There is the need for proper placement of base transceiver station in and around neighborhoods to enhance information technology. Conclusively, this study has successfully designed a neighborhood control model which can be used in the placement of base transceiver station in the neighborhoods of Nigeria Cities.

7. CONTRIBUTIONS TO KNOWLEDGE

In this study, we successfully design the proposed Base Transceiver Station Neighborhood model using Genetic Algorithm approach. It caters for proper placement of the base station in the natural environment by taking into consideration the health issues of the population living there.

REFERENCES

1. Aderoju, O.M., Godstime, J., Olojo, O., Oyewumi, A., Eta, J., Onuoha, H.U., Salman, K., and Nwadike, B.K. (2014) Space-Based Assessment of the Compliance of GSM Operators in Establishing Base Transceiver Station (BTS) In Nigeria Using Abuja Municipal Area Council as Case Study. *IOSR Journal of Environmental Science, Toxicology and Food Technology*. Volume 8, Issue 10. PP 46-57
2. Alabi, I. K., Sagir, L., Fatai, O. A., and Alabi, I.I. (2017).GSM Quality of Service Performance in Abuja, Nigeria. *International Journal of Computer Science, Engineering and Applications (IJCSEA)* Vol. 7, No. 3/4, pages 29-40.
3. Badru, R.A., Alwadood, J.A., Atijosan, A.O., Oloko-Oba, M.A., Babalogbon, B.A., Jesuleye, I.A., Alaga, T.A, and Shaba H.A. (2016). Evaluation Of Geo-Spatial Proximity Of Mobile Communication (GSM) Base Transceiver Stations To Buildings In Ile-Ife, Nigeria. *International Journal of Scientific & Technology Research* Volume 5, ISSUE 02, Pages 87-91.
4. Bakare, B.I. Ekanem, I.A., and Allen, I.O. (2017) Appraisal of Global System for Mobile Communication (GSM) In Nigeria. *American Journal of Engineering Research (AJER)* e-ISSN: 2320-0847 p-ISSN : 2320-0936 Volume-6, Issue-6, pp-97-102
5. Bello, M. O. (2010). Effects of the Location of GSM Base Stations on Satisfaction of Occupiers and Rental Value of Proximate Residential Property. *Computer and Information Science*, 3 (4): 159 - 170.
6. Chieme, A. and Obiora, O. (2014). Wireless Communication: The Impact of GSM on the Economic Lives of the Nigerian Rural Users. *Journal of Educational and Social Research*, 4 (7): 79-87.
7. Elegbeleye, O.S. (2005). Prevalent Use of Global System of Mobile Phone (GSM) for Communication in Nigeria: A Breakthrough in Interactional Enhancement or a Drawback? *Nordic Journal of African Studies*, 14(2): 193-207
8. Enyinna, P. I. and Avwir, G.O. (2010).Characterization of the Radio Frequency Radiation Potential of Alakahia and Choba Communities, Nigeria. *FACTA UNIVERSITATIS Series: Working and Living Environmental Protection* Vol. 7, No 1, 2010, pp. 25 - 31
9. Husain, M. A., Gwary, M. S., Yusuf, M. I. and Yusuf, I. D. (2017).Appraisal of Spatial Distribution of Global System for Mobile Telecommunications (GSM) Infrastructure in Gombe Metropolis, Nigeria.*International Journal of Engineering Science Invention* ISSN (Online): 2319 - 6734, ISSN (Print): 2319 - 6726 www.ijesi.org. Volume 6 Issue 8.Pages. 45-55
10. Job, M. Anish, K. and Ben, V.W. (2008).Optimization of Antenna Placement in 3G Networks using Genetic Algorithms.Third International Conference on Broadband Communications, Information Technology & Biomedical Applications. *Journal of Computer Society*, Pp30 - 37.
11. Joseph I. (2013). Harnessing Telecommunications Revolution in Nigeria: A Case Study.*Wireless and Mobile Technologies*1, no. 1, pp. 20-24.
12. Micah D. J. and Alabi, J. T. (2016). Challenges of operators of global system for mobile telecommunication services in Nigeria: towards mitigating the pain. *Direct Research Journal of Social Science and Educational Studies (DRJSES)*. Vol. 3(3), pp. 44-50.



13. Mouly, M. and Pautet, M. B. (1991). GSM Protocol Architecture: Radio Subsystem Signaling. IEEE 41st Vehicular Technology Conference
14. Muñoz-Gea, J. P. Vales-Alonso, J. García-Haro, J. González-Castaño, F. J. (2006). A Simulation Study on the Health Concerns Derived from GSM Base Station Placement. IEEE MELECON, Benalmadena (Malaga), Spain 1-4244-0088-0/06
15. Oliver, B. and Danielle, S. (2005). Regulating the Risks of Mobile Phone Base Stations a Comparative Study in five Countries. World Health Organization workshop on base stations and wireless network, 113-126
16. Olukotun, G. A., James, O. O. and Olorunfemi, K. (2013). The Introduction of GSM Services in Anyigba Community and its Impact on Students Expenditure Pattern. Global Journal of Management and Business Research Finance, 13 (8): 71-81.
17. Omirin, M.S. and Olutuase, T.O. (2007). The Effect of GSM on Reading Culture of Student/Users of the Library: A Case Study of the University of Ado-Ekiti, Nigeria. The Social Sciences Medwell Journals, 2(2): 139-141.
18. Thomas, A. W. (2002). Cell Towers proliferation in the United States. The geographical review, 92(1) 46-62 published by the geographical society of New York
19. Udomisor, I.W., Akoje, S. P. E. and Udomisor, E.I. (2015). Impacts of Mobile Technology on Nigeria Broadcasting Communication Policy. International Journal of Social Science Studies, 3 (1): 111-121.